



MSAG

Metal Standard Aerosol Generation



IAS Inc.

MSAG is an indispensable tool for nano-particle analysis and direct gas analysis such as laser ablation (LA) and Gas Exchange Device (GED) by ICP-MS

Features

- ◆ High precision syringe pump can introduce metal standard solution at a **1 $\mu\text{L}/\text{min}$** to a nebulizer and a 100% of solution is introduced to the plasma of ICP-MS. As a result, the absolute amount of each element, e.g. **ag/sec** and **atoms/sec**, introduced to the plasma can be calculated. As a result, **analysis of standard nano-particle such as Au is not required.**
- ◆ ICP-MS signal detected, e.g. **counts/sec**, from the standard solution above gives the sensitivity of each element in **ag/count**.
- ◆ Transient signal analysis of ICP-MS can detects particles, which gives absolute amount of each element in **ag**, which can calculate **diameter** of one particle.
- ◆ Concentration of metallic impurities in gases in **ng/kg** or **ng/m³** can be calculated as well as the particle size distribution of each element.
- ◆ Metal free structure for all contact parts with standard solution.

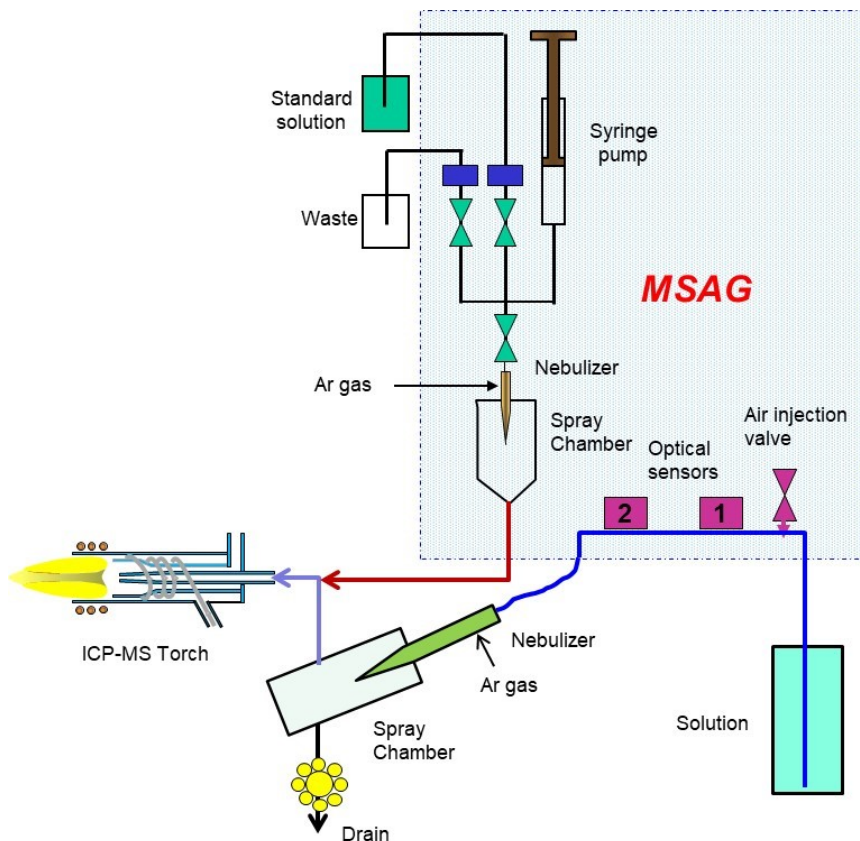

MSAG for nano particle analysis in solution

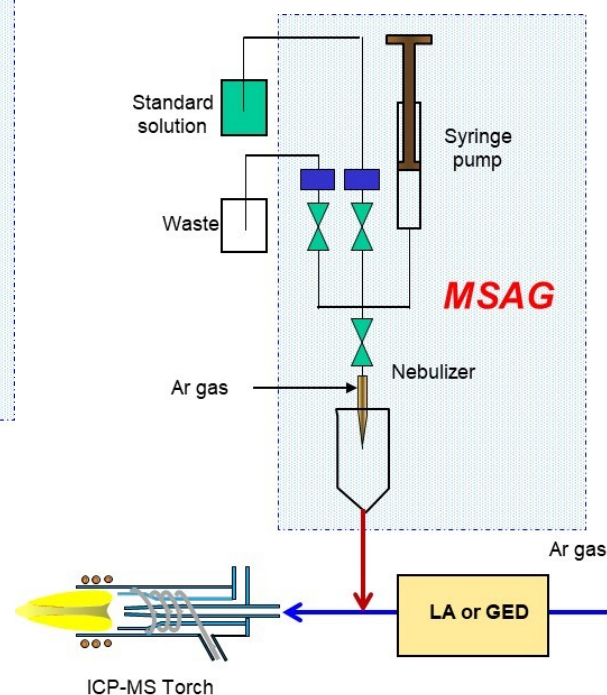

Nano particle analysis in gas

Calibration Curve by MSAG

- A 10 ng/mL mixed metal standard solution was directly introduced to a nebulizer from 0 to 3 $\mu\text{L}/\text{min}$ by means of MSAG.
- MSGG (Metal Standard Gas Generation) unit was also used to monitor variation of ICP-MS sensitivity, and Mo gaseous standard was used as an internal standard.
- Linear calibration curves with internal standard correction were obtained below 3 $\mu\text{L}/\text{min}$.
- Three different nebulizer was checked with a 1 $\mu\text{L}/\text{min}$ flow rate, and reproducible results were obtained, which indicated that a 100% of standard solution introduced to the nebulizer was introduced to the plasma of ICP-MS.
- When the standard solution was introduced over 3 $\mu\text{L}/\text{min}$, the sensitivity started decreasing, which indicated that some portion of standard solution was trapped in a spray chamber.

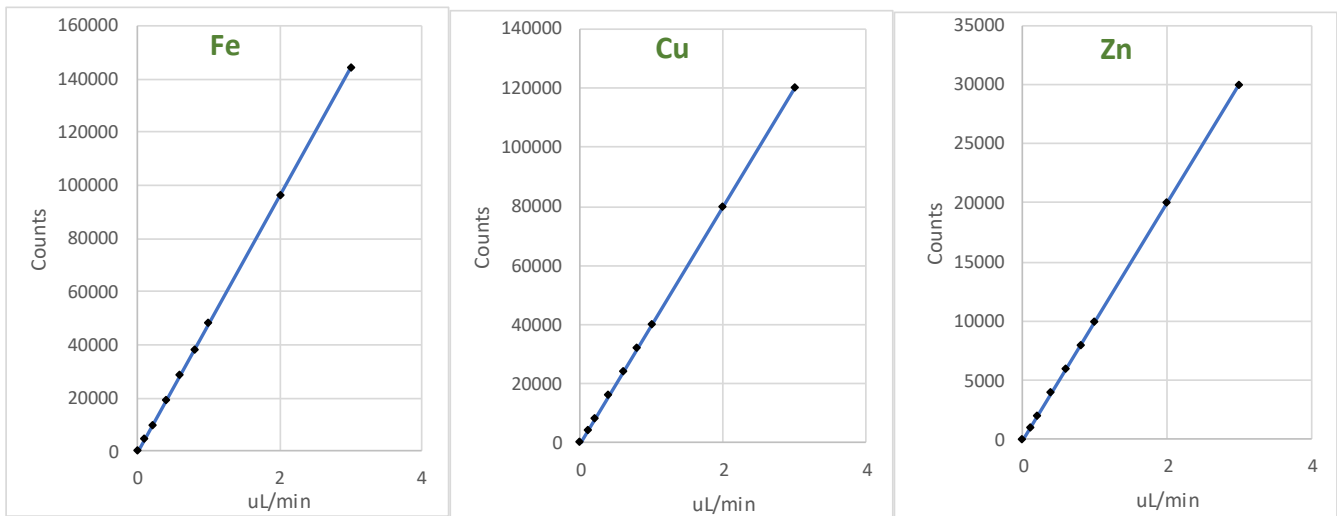

	MSAG			MSGG		
	51V	208Pb	238U	52Cr	95Mo	182W
Nebulizer 1	35,278	378,438	798,065	111,615	45,460	88,481
Nebulizer 2	36,077	391,145	829,978	111,389	44,435	88,354
Nebulizer 3	35,732	393,829	833,304	110,553	44,054	86,670
SD	401	8,221	19,456	559	727	1,011
Average	35,695	387,804	820,449	111,186	44,650	87,835
RSD (%)	1.12	2.12	2.37	0.50	1.63	1.15

(Unit : count)

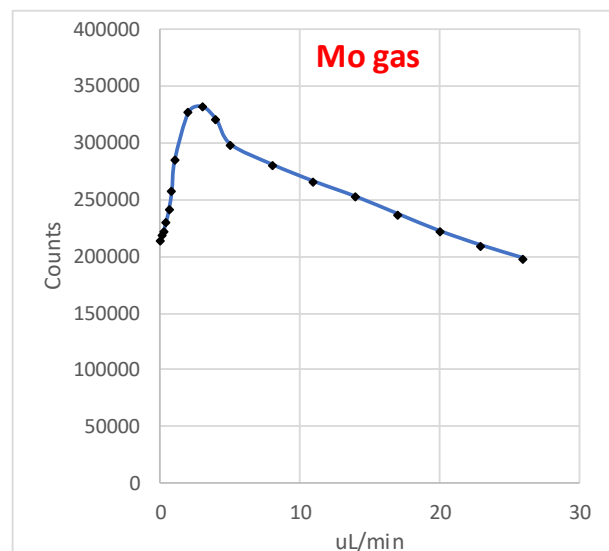
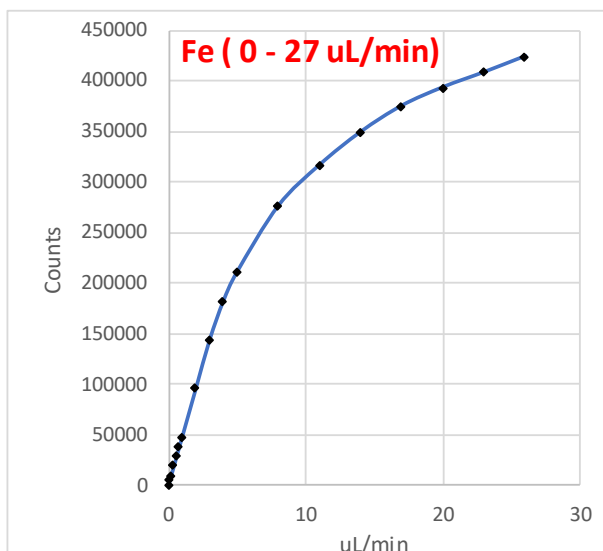

Counts in Y axis is compensated intensity with Mo internal standard based on the count obtained at 1 $\mu\text{L}/\text{min}$ uptake rate

Metal Particle Analysis in NH₃ Gas by GED

- ◆ Many particles of Cu and Zn were detected in a high purity NH₃ gas by GED-ICP-MS.
- ◆ The concentration of Cu and Zn was calculated aqueous standard solution 0.48 and 0.07 ng/kg, respectively.
- ◆ One particle with 5 counts signal was equivalent to 30 and 36 nm particle size of pure Cu and Zn, respectively.

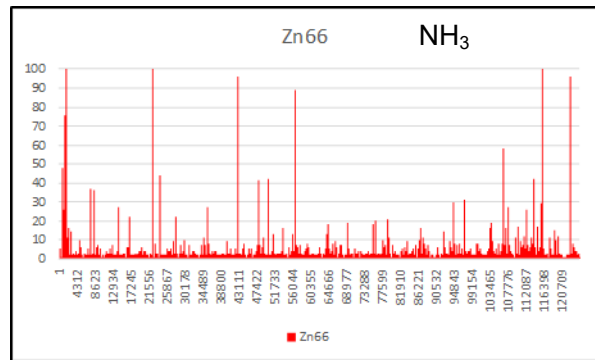
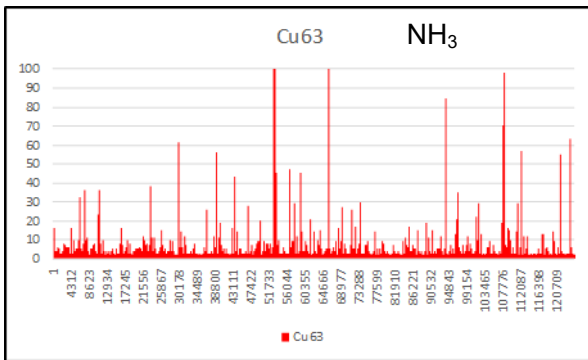
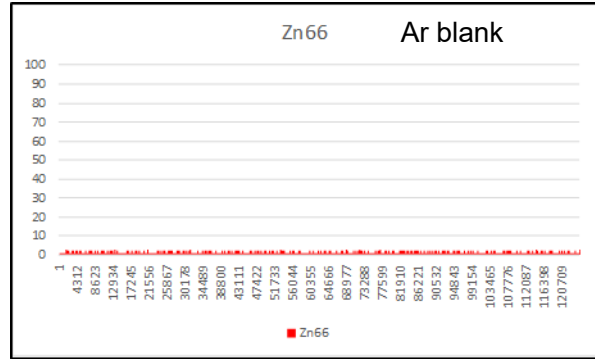
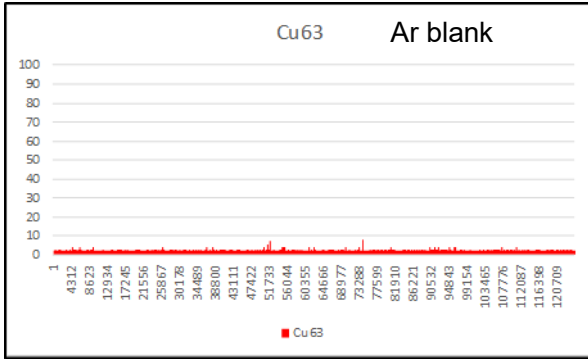

Specifications

Model : MSAG
Flow range : 0.10 - 3.00 µL/min
Syringe : Glass 500 µL
Nebulizer : High efficiency concentric
Spray chamber : Glass

Environment & Utilities
Room temp. : 15 - 30°C
Humidity : 35 - 85%RH, no condensation
Power : 100 - 240 VAC ±10% 2 A,
Single phase, 50/60 Hz
Size : 166(W) x 295(D) x 630(H) mm
Weight : 7 kg

IAS Inc.

2-2-1 Hinohonmachi, Hino, Tokyo, 191-0011 Japan
TEL: +81-42-511-2964 FAX: +81-3-4570-0341
E-Mail: iasjapan@iasinc.jp URL: <https://iasinc.jp>

